

# Model Documentation of the Distillation Column

## 1 Nomenclature

### 1.1 Nomenclature for Model Equations

$K_{R1}, T_{N1}$	parameters of the first PI controller
$K_{R2}, T_{N2}$	parameters of the second PI controller
$K_1, K_2, K_3, K_4, T_1$	parameters of the model, equilibrium point
$x_S$	filling level
$x_T$	temperature on the bottom
$z_{ii}$	malfunctions for $i = 1, 2$
$fb_i$	feedback for $i = 1, 2$
$w$	supply of heat steam, equivalent to $M_H$

### 1.2 Signal Flowchart

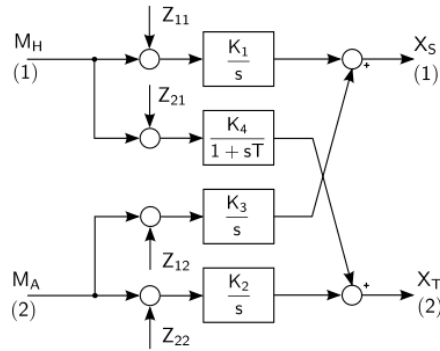

Figure 1: Signal Flowchart

## 2 Model Equations

State Vector and Input Vector:

$$\underline{x} = (x_S \ x_T)^T = (x_1 \ x_2)^T$$

$$\underline{u} = (fb_1 \ fb_2 \ w \ z_{11} \ z_{21} \ z_{12} \ z_{22}) = (u_1 \ u_2 \ u_3 \ u_4 \ u_5 \ u_6 \ u_7)^T$$

Transfer Functions:

$$G_{R_{11}} = K_{R1} \left( 1 + \frac{1}{sT_{N1}} \right) \quad (1a)$$

$$G_{R_{22}} = K_{R2} \left( 1 + \frac{1}{sT_{N1}} \right) \quad (1b)$$

$$G_{P_{11}} = \frac{K_1}{s} \quad (1c)$$

$$G_{P_{12}} = \frac{K_4}{1 + sT} \quad (1d)$$

$$G_{P_{21}} = \frac{K_3}{s} \quad (1e)$$

$$G_{P_{22}} = \frac{K_2}{s} \quad (1f)$$

Parameters:  $K_{R1}, T_{N1}, K_{R2}, T_{N2}, T_1, K_1, K_2, K_3, K_4$   
 Outputs:  $x_1, x_2$

## 2.1 Exemplary parameter values

Symbol	Value
$K_{R1}$	1.7
$T_{N1}$	1.29
$K_{R2}$	0.57
$T_{N2}$	1.29
$T_1$	1
$K_1$	0.4
$K_2$	1.2
$K_3$	-0.8
$K_4$	-0.2

## 3 Derivation and Explanation

A rough analysis of the column behavior leads to the following approaches for the four subtransfer functions:

$$\frac{X_S}{M_H} = \frac{K_1}{s}; \quad \frac{X_T}{M_A} = \frac{K_2}{s}; \quad \frac{X_S}{M_A} = \frac{K_3}{s}; \quad \frac{X_T}{M_H} = \frac{K_4}{1 + sT}.$$

$M_H$  is standing for the supply of the heat steam and  $M_A$  represents the drain of the product. The system model is based on the signal flowchart.

## 4 Simulation

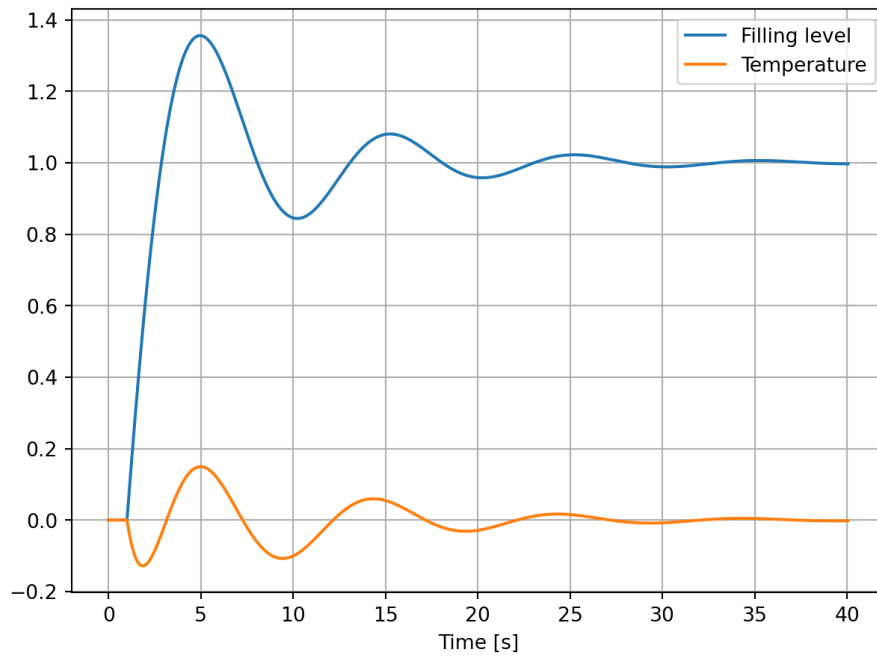

Figure 2: Simulation of the distillation column.

## References

- [1] Institut of Control Theory TU Dresden: *Regelungstechnikpraktikum, Praktikumsanleitung*, published in OPAL April 2022.  
(not publicly accessible)
- [2] Knoll, Carsten: *Example2 : linear system consisting of various blocks*, Python Script published 2019.  
<https://github.com/TUD-RST/pyblocksim/blob/master/examples/example2.py>