

# Model Documentation of the PVTOL with 2 Forces

## 1 Nomenclature

### 1.1 Nomenclature for Model Equations

$x$	horizontal displacement
$y$	vertical displacement
$\theta$	roll angle
$F_1, F_2$	Forces on the left and right site of the PVTOL
$g$	acceleration due to gravity
$l$	distance between mass center of PVTOL and target point of the forces
$m$	mass of the PVTOL
$J$	moment of inertia of the PVTOL

### 1.2 Graphic of the Structure

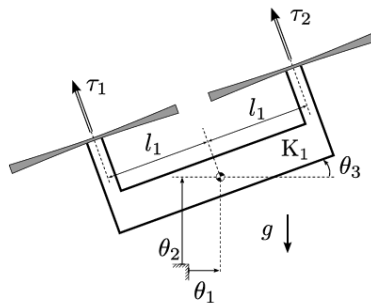

Figure 1: Structure of the PVTOL Model.

Source: Knoll, Carsten / [https://nbviewer.org/github/cknoll/beispiele/blob/master/senkrechtstarter\\_pvtol\\_koordinatentransformation.ipynb](https://nbviewer.org/github/cknoll/beispiele/blob/master/senkrechtstarter_pvtol_koordinatentransformation.ipynb)

## 2 Model Equations

State Vector and Input Vector:

$$\underline{x} = (x_1 \ x_2 \ x_3 \ x_4 \ x_5 \ x_6)^T = (x \ \dot{x} \ y \ \dot{y} \ \theta \ \dot{\theta})^T$$
$$\underline{u} = (u_1 \ u_2)^T = (F_1 \ F_2)^T$$

Model Equations:

$$\dot{x}_1 = x_2 \tag{1a}$$

$$\dot{x}_2 = -\frac{\sin(x_5)}{m}(u_1 + u_2) \tag{1b}$$

$$\dot{x}_3 = x_4 \tag{1c}$$

$$\dot{x}_4 = \frac{\cos(x_5)}{m}(u_1 + u_2) - g \tag{1d}$$

$$\dot{x}_5 = x_6 \tag{1e}$$

$$\dot{x}_6 = \frac{l}{J}(u_2 - u_1) \tag{1f}$$

Parameters:  $m, J, l, g$

Outputs:  $x, y, \theta$

## 2.1 Assumptions

1. Forces target the body of the PVTOL in a 90° angle.

## 2.2 Exemplary parameter values

Parametername	Symbol	Value	Unit
acceleration due to gravity	$g$	9.81	$\frac{\text{m}}{\text{s}^2}$
distance of forces to mass center	$l$	0.1	m
mass	$m$	0.25	kg
moment of inertia	$J$	0.00076	$\text{kg} \cdot \text{m}^2$

## 3 Derivation and Explanation

The Lagrangian mechanics was used for the solution.

## 4 Simulation

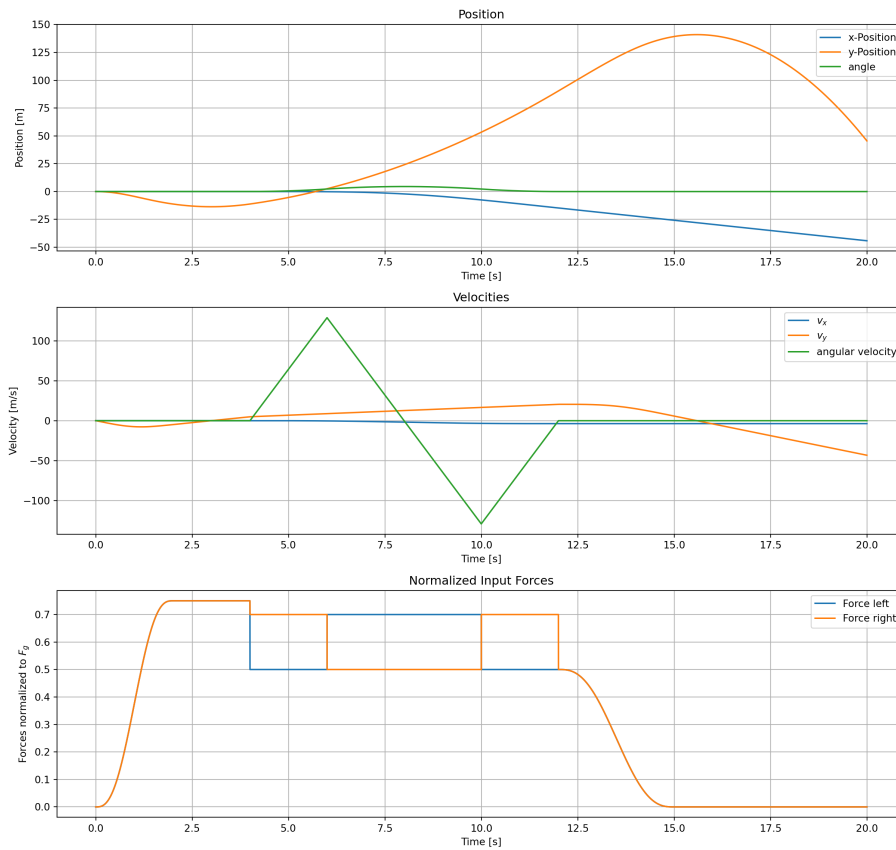

Figure 2: Simulation of the PVTOL with 2 forces.

## References

- [1] Knoll, Carsten: *Regelungstheoretische Analyse- und Entwurfsansätze für unteraktuierte mechanische Systeme*, p. 169, TU Dresden, 2016.
- [2] Knoll, Carsten: *Senkrechtstarter in der vertikalen Ebene*, Jupyter Notebook published 2016.  
[https://nbviewer.org/github/cknoll/beispiele/blob/master/senkrechtstarter\\_pvtol\\_koordinatentransformation.ipynb](https://nbviewer.org/github/cknoll/beispiele/blob/master/senkrechtstarter_pvtol_koordinatentransformation.ipynb)